



Leckage- scheibenventile

Leakage butterfly valves

Válvulas de mariposa
con escape

L4



KIESELMANN
FLUID PROCESS GROUP

Kurzübersicht	Overview	Resumen	
Leckage-Scheibenventil ohne Flansch	Leakage butterfly valve	Válvula de mariposa con escape	4.23
Leckage-Scheibenventil S-S mit Flansch PN 10, Nr. 2069	Leakage butterfly valve with flange	Válvula de mariposa con escape con brida	4.23
Leckage-Scheibenventil S-S mit Flansch PN 10, Nr. 2041	Leakage butterfly valve with flange	Válvula de mariposa con escape con brida	4.24
Leckage-Scheibenventil S-S mit Flansch PN 10, Nr. 2041, Zoll	Leakage butterfly valve with inch flange	Válvula de mariposa con escape con brida en pulgadas	4.24
Leckage-Scheibenventil G-S	Leakage butterfly valve	Válvula de mariposa con escape	4.25
Leckage-Scheibenventil K/M-G	Leakage butterfly valve	Válvula de mariposa con escape	4.25
Spezial-Dichtung für Leckage-Scheibenventil	Leakage butterfly valve seal	Juntas de repuesto para válvula de mariposa con escape	4.26
Anschlussstutzen für Reinigungsanschluss	Cavity connection	Racores macho para limpieza	4.26
Ersatz-Handhebel	Butterfly lever	Palanca de mano substituta	4.26
Handhebel mit Halter für Endlagerückmeldeschalter	Manual lever with proximity switch bracket	Palanca de mano con soporte para indicador de posición	4.26
Pneumatik-Drehantrieb für nachträglichen Aufbau	90° pneumatic actuator kit	Actuador neumático para instalación posterior	4.27
Sensor, induktiv	Proximity switch	Sensor inductivo de proximidad	4.27
Elektronischer Steuerkopf	Control head	Cabecal de mando electrónico	4.27

Die Ersatzteilsätze befinden sich hinter den jeweiligen Produkten.
 The spare parts kit can be found at the end of each chapter.
 Los juegos de respuestos se encuentran al fin de cada capítulo.



LECKAGE-SCHEIBENVENTILE

Leckage-Scheibenventil ohne Flansch, handbetätigt

leakage butterfly valve, manual · vanne papillon avec chambre de fuite, manuelle · válvula de mariposa con escape func., manual

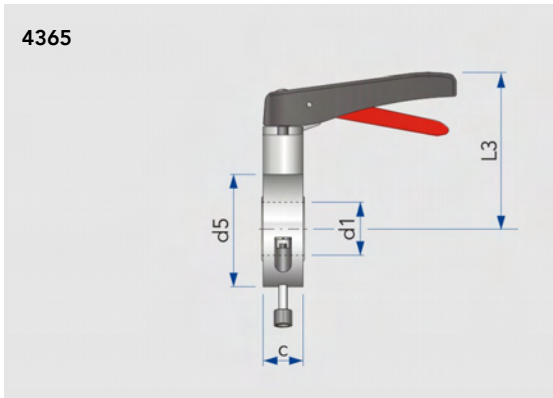

DN	Zoll	d1	d5	c	L3	kg
50		50,0	110	38	148	2,18
65		66,0	130	38	158	2,88
	3"	72,1	146	41	167	3,49
80		81,0	146	41	167	4,06
100		100,0	166	41	178	5,29
125		125,0	195	53	214	8,32

Leckage-Scheibenventil ohne Flansch, pneum. betätigt

leakage butterfly valve, pneumatic · vanne papillon avec chambre de fuite, pneum. · válvula de mariposa con escape, func. neumático

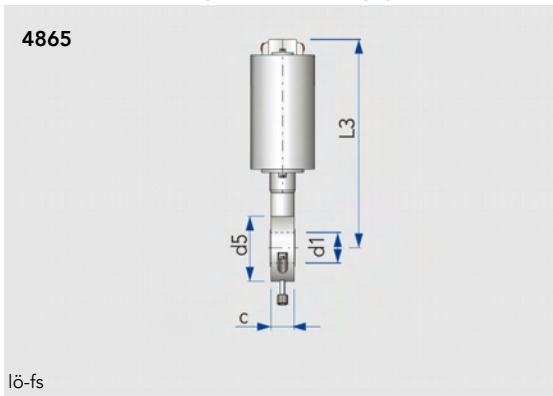

DN	Zoll	d1	d5	c	L3	kg
50		50,0	110	38	338	6,74
65		66,0	130	38	349	7,45
	3"	72,1	146	41	358	8,05
80		81,0	146	41	358	8,38
100		100,0	166	41	407	12,23
125		125,0	195	53	421	16,31

lö-fs

Leckage-Scheibenventil S-S, komplett mit Flansch PN 10 Nr. 2069, handbetätigt

leakage butterfly v. w. flanges pneum. · v. papillon a. chambre de fuite a. brides pneum. · válvula de mariposa con escape compl. con brida func. neum.

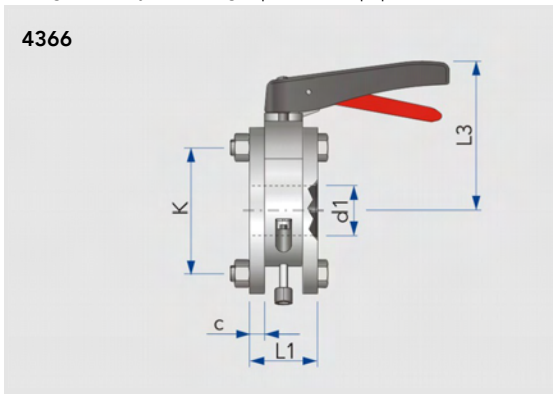

DN	d1	c	K	L1	L3	kg
50	50	15	125	68	148	7,40
65	66	15	145	68	158	8,29
80	81	15	160	71	167	9,16
100	100	15	180	70	178	10,80
125	125	17	210	87	214	17,58

Leckage-Scheibenventil S-S, komplett mit Flansch PN 10 Nr. 2069, pneum. betätigt

leakage butterfly v. w. flanges pneum. · v. papillon a. chambre de fuite a. brides pneum. · válvula de mariposa con escape compl. con brida, func. neum.

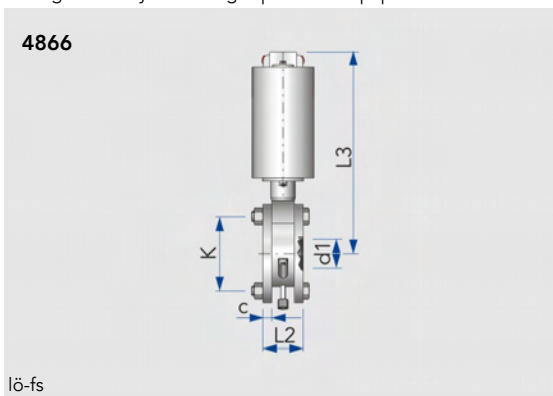

DN	d1	c	K	L2	L3	kg
50	50	15	125	68	338	11,94
65	66	15	145	68	349	13,51
80	81	15	160	71	358	15,40
100	100	15	180	70	407	20,36
125	125	17	210	87	421	25,57

lö-fs



LECKAGE-SCHEIBENVENTILE

Leckage-Scheibenventil S-S, komplett mit Kleinflansch Nr. 2041, handbetätigt

leakage butterfly, v. man., with flanges · v. papillon a. chambre de fuite a. brides man. · v. de mariposa con escape completa c. brida, func. man.

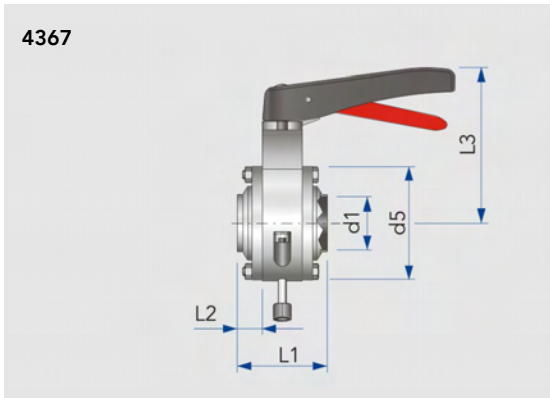

DN	d1	d5	L1	L2	L3	kg
50	50,0	108	86	24	148	3,64
65	66,0	130	86	24	158	4,86
80	81,0	146	89	24	167	5,83
100	100,0	166	88	24	178	7,62
125	125,0	205	99	23	181	11,60

Leckage-Scheibenventil S-S, komplett mit Kleinflansch Nr. 2041, pneum. betätigt

leakage butterfly v., pneum., with flanges · v. papillon a. chambre de fuite a. brides pneum. · v. de mariposa con escape completa c. brida, func. neum.

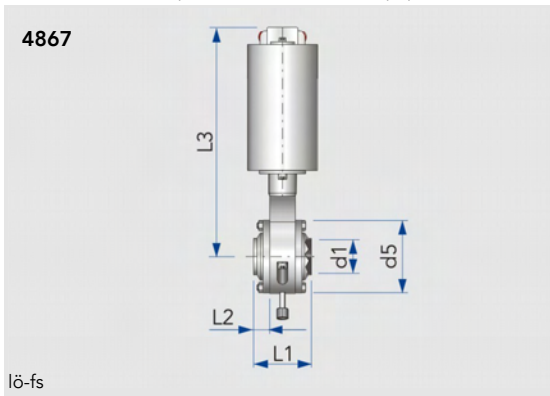

DN	d1	d5	L1	L2	L3	kg
50	50,0	108	86	24	339	8,22
65	66,0	130	86	24	349	9,45
80	81,0	146	89	24	358	10,38
100	100,0	166	88	24	409	15,42
125	125,0	205	99	23	402	18,60

Leckage-Scheibenventil S-S, komplett mit Zoll Kleinflansch Nr. 2041, handbetätigt

leakage butterfly v., man., with inch flanges · v. papillon a. chambre de fuite a. brides man. · v. de mariposa con escape, completa c. brida func. man.

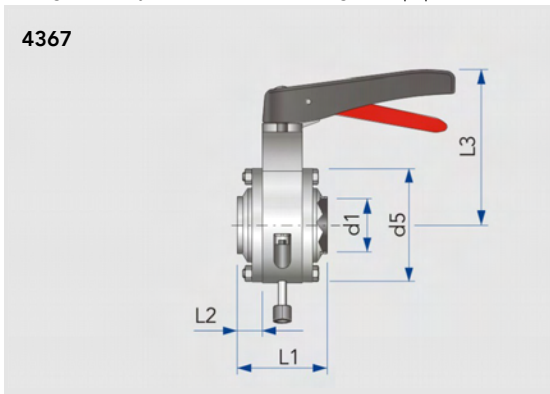

Zoll	d1	d5	L1	L2	L3	kg
2"	47,8	108	86	24	148	3,71
2½"	60,3	130	86	24	158	5,02
3"	72,1	146	89	24	167	6,41
4"	97,6	166	88	24	178	7,01

Leckage-Scheibenventil S-S, komplett mit Zoll Kleinflansch Nr. 2041, pneum. betätigt

leakage butterfly v., pneum., with inch flanges · v. papillon a. chambre de fuite a. brides pneum. · v. de mariposa con escape completa c. brida func.

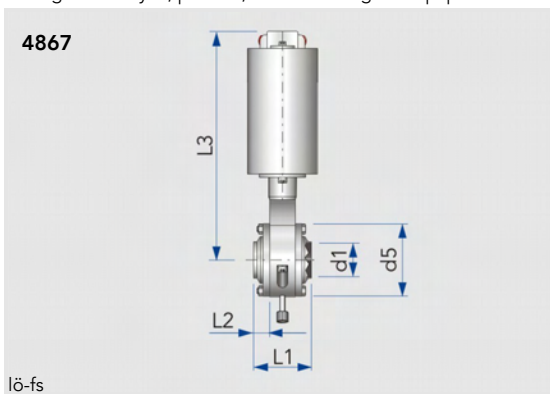

Zoll	d1	d5	L1	L2	L3	kg
2"	47,8	108	86	24	339	8,30
2½"	60,3	130	86	24	349	9,58
3"	72,1	146	89	24	358	10,95
4"	97,6	166	88	24	409	15,25



Leckage-Scheibenventil G-S, handbetätigt

leakage butterfly valve ,manual · vanne papillon avec chambre de fuite, man. · válvula de mariposa con escape, func. man.

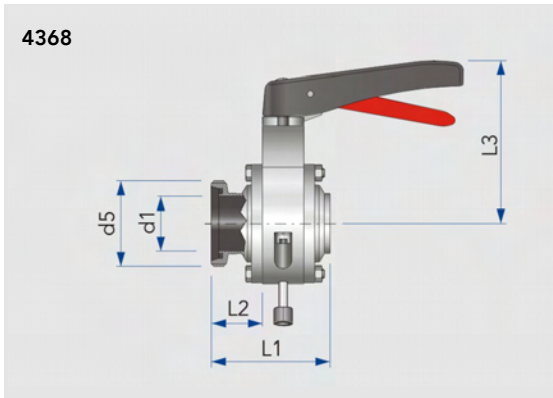

DN	d1	d5	L1	L2	L3	kg
50	50,0	Rd 78×¼	109	47	148	3,82
65	66,0	Rd 95×¼	111	49	158	5,13
80	81,0	Rd110×¼	114	49	167	5,96
100	100,0	Rd130×¼	118	54	178	7,50
125	125,0	Rd160×¼	145	69	214	13,54

Leckage-Scheibenventil G-S, pneum. betätigt

leakage butterfly valve, pneumatic · vanne papillon avec chambre de fuite, pneum. · válvula de mariposa con escape, func. neum.

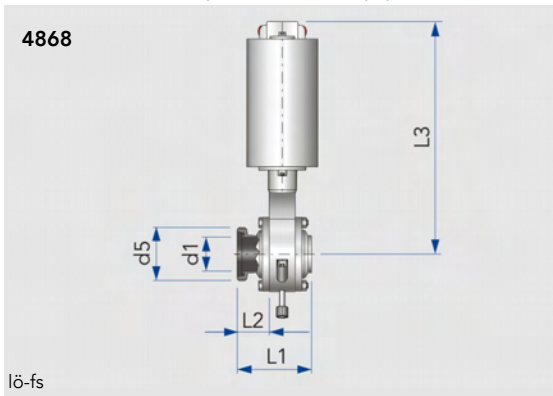

DN	d1	d5	L1	L2	L3	kg
50	50,0	Rd 78×¼	109	47	338	8,32
65	66,0	Rd 95×¼	111	49	349	9,71
80	81,0	Rd110×¼	114	49	358	10,69
100	100,0	Rd130×¼	118	54	407	15,79
125	125,0	Rd160×¼	145	69	421	21,18

Leckage-Scheibenventil K/M-G, handbetätigt

leakage butterfly valve, manual · vanne papillon avec chambre de fuite, man. · válvula de mariposa con escape, func. man.

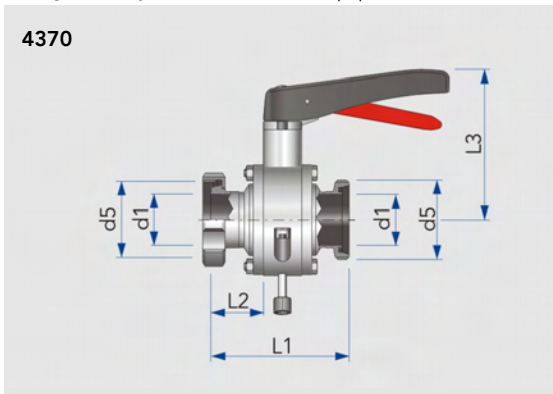

DN	d1	d5	L1	L2	L3	kg
50	50	Rd 78×¼	137	52	148	4,29
65	66	Rd 95×¼	143	56	158	5,94
80	81	Rd110×¼	151	61	167	7,05
100	100	Rd130×¼	162	68	178	9,03
125	125	Rd160×¼	179	57	214	15,85

Leckage-Scheibenventil K/M-G, pneum. betätigt

leakage butterfly valve, pneumatic · vanne papillon avec chambre de fuite, pneum. · válvula de mariposa con escape, func. neum.

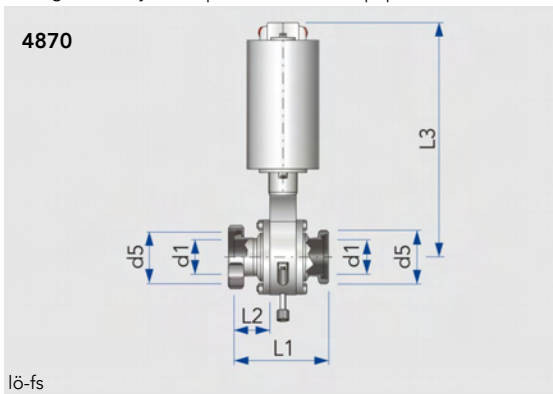

DN	d1	d5	L1	L2	L3	kg
50	50	Rd 78×¼	137	52	339	8,86
65	66	Rd 95×¼	143	56	349	10,51
80	81	Rd110×¼	151	61	358	11,59
100	100	Rd130×¼	162	68	407	16,89
125	125	Rd160×¼	179	57	421	23,73



LECKAGE-SCHEIBENVENTILE

Spezial-Dichtung, für Leckage-Scheibenventil

leakage butterfly valve seal · joint de rechange pour vanne papillon avec chambre de fuite · junta de repuesto para válvula de mariposa con escape

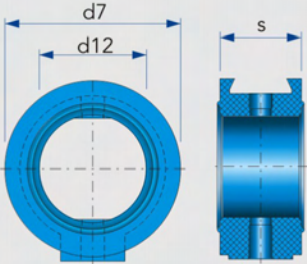
4377 4378	DN	Zoll	d7	d12	s	kg
	50	3"	82,0	50	38	0,09/0,11
	65		96,0	65	38	0,12/0,13
	80		103,1	71	41	0,14/0,16
	100		112,0	80	41	0,15/0,17
	125		133,0	100	41	0,19/0,22
			162,0	125	53	0,30

G-Schlauch-/S-Stutzen, für Reinigungsanschluss

cavity connections · manchon fileté pour connection de nettoyage · racores macho para limpieza

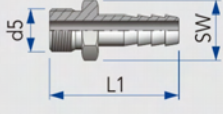
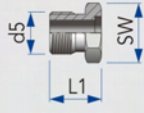
4380 4381	Zoll	d5	L1	SW	kg
 <p>Schlauch \varnothing = 9 mm (innen)</p>	1/4"	G3/4	40/18	17	0,02/0,01
 <p>Rohr 10 x 1 mm</p>					

Ersatz-Handhebel

butterfly lever · poignée · palanca de mano substituta

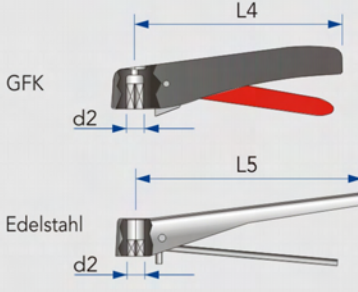
4335 4318	DN	d2	L4	L5	m. Feder	kg
 <p>GFK</p> <p>Edelstahl</p>	50-80	10	165			0,14
	100	12		180		0,33
	125	14		285		0,75

Weitere Farben in GFK auf Anfrage

Handhebel, für Leckage-Scheibenventil, handbetätigt mit Halter für Sensor, induktiv

manual lever with proximity switch bracket · poignée · pal. de mano p. v. de marip. c. escape func. man. c. soporte p. indic. de posic.

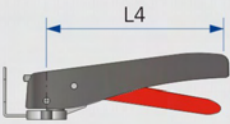
4039	DN	Zoll	L4	kg
	50-65	3"		0,21
	80			0,22
	100			0,40
	125			0,93

Bestehend aus:
Arretierscheibe mit Aufnahmevorrichtung,
Handgriff mit Schaltknocken



